

APZT222A-HF (NPN)

RoHS Device
Halogen Free

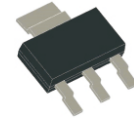

Features

- Epitaxial planar die construction.
- Ideal for low power amplification and switching.
- AEC-Q101 Qualified.

Mechanical data

- Case: SOT-223, molded plastic.
- Molding compound: UL flammability classification rating 94V-0.
- Terminals: Tin-plated, solderability per MIL-STD-202, method 208.

Circuit Diagram

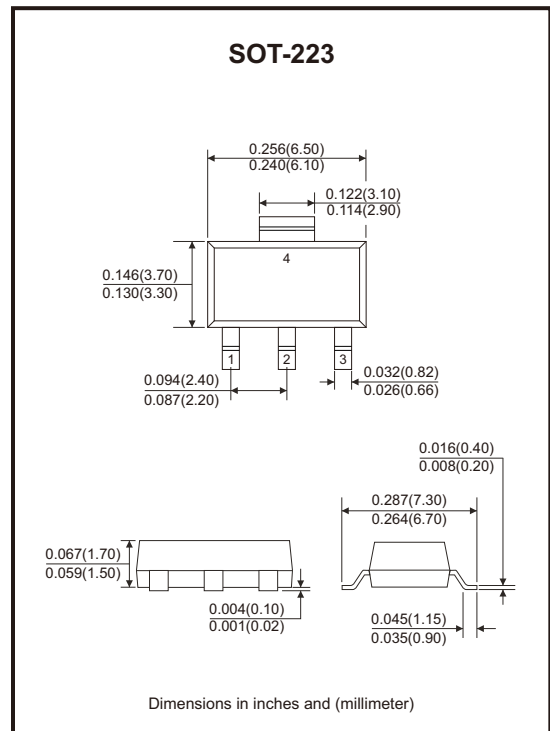
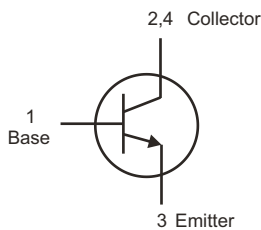

Maximum Ratings (at Ta=25°C unless otherwise noted)

Parameter	Symbol	Value	Units
Collector-base breakdown voltage	V _{CBO}	75	V
Collector-emitter breakdown voltage	V _{CEO}	40	V
Emitter-base breakdown voltage	V _{EB0}	6	V
Collector current (continuous)	I _C	0.6	A
Collector current-peak pulse width ≤ 40μs, δ = 0.35	I _{CM}	1.5	A
Power dissipation (collector) (Note 1)	P _D	1.15	W
Thermal resistance, junction to ambient	R _{θJA}	108	°C/W
Junction temperature range	T _J	-55 to +150	°C
Storage temperature range	T _{STG}	-55 to +150	°C

Note: 1. Device mounted on a printed-circuit board, single-sided copper, tinplated, mounting pad for collector 1cm².

Electrical Characteristics (Ta=25°C, unless otherwise specified)

Parameter	Conditions	Symbol	Min.	Max.	Unit
Collector-base breakdown voltage	$I_C = 10\mu A, I_E = 0$	$V_{(BR)CBO}$	75		V
Collector-emitter breakdown voltage	$I_C = 10mA, I_B = 0$	$V_{(BR)CEO}$	40		V
Emitter-base breakdown voltage	$I_E = 10\mu A, I_C = 0$	$V_{(BR)EBO}$	6		V
Collector cut-off current	$V_{CB} = 60V, I_E = 0$	I_{CBO}		10	nA
Collector cut-off current	$V_{CB} = 60V, V_{EB(OFF)} = -3V$	I_{CEX}		10	nA
Base cut-off current	$V_{EB} = 3V, I_C = 0$	I_{EBO}		10	nA
DC current gain	$V_{CE} = 10V, I_C = 0.1mA$	h_{FE}	35		
	$V_{CE} = 10V, I_C = 1mA$	h_{FE}	50		
	$V_{CE} = 10V, I_C = 10mA$	h_{FE}	75		
	$V_{CE} = 10V, I_C = 150mA$	h_{FE}	100	300	
	$V_{CE} = 10V, I_C = 500mA$	h_{FE}	40		
Collector-emitter saturation voltage	$I_C = 150mA, I_B = 15mA$	$V_{CE(sat)}$		0.3	V
	$I_C = 500mA, I_B = 50mA$	$V_{CE(sat)}$		1	
Base-emitter saturation voltage	$I_C = 150mA, I_B = 15mA$	$V_{BE(sat)}$		1.2	V
	$I_C = 500mA, I_B = 50mA$	$V_{BE(sat)}$		2	
Output capacitance	$V_{CB} = 10V, I_E = 0, f = 1MHz$	C_{OBO}		8	pF
Input capacitance	$I_C = 0, V_{EB} = 0.5V, f = 1MHz$	C_{IBO}		25	pF
Transition frequency	$I_C = 20mA, V_{CE} = 20V, f = 100MHz$	f_T	300		MHz
Delay time	$V_{CC} = 30V, I_C = 150mA, I_{B1} = 15mA$	t_d		10	ns
Rise time		t_r		25	
Storage time		t_s		225	
Fall time	$V_{CC} = 30V, I_C = 150mA, I_{B1} = I_{B2} = 15mA$	t_f		60	ns

Rating and Characteristic Curves (APZT2222A-HF)

Fig.1 - $h_{FE} - I_c$

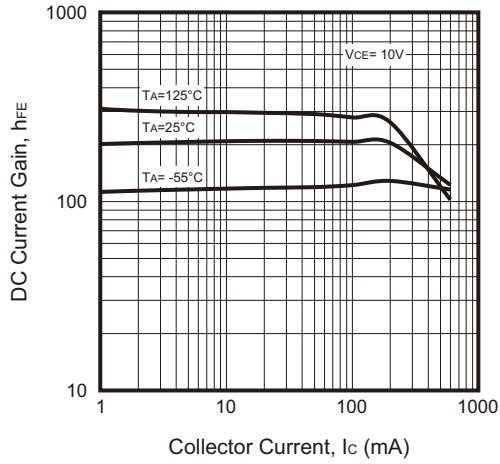

Fig.2 - $V_{CE(sat)} - I_c$

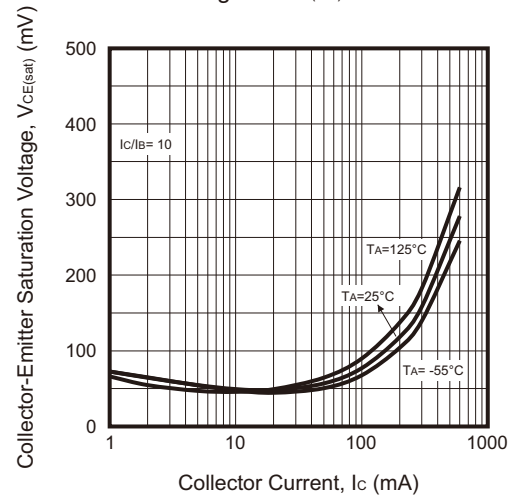

Fig.3 - $V_{BE(sat)} - I_c$

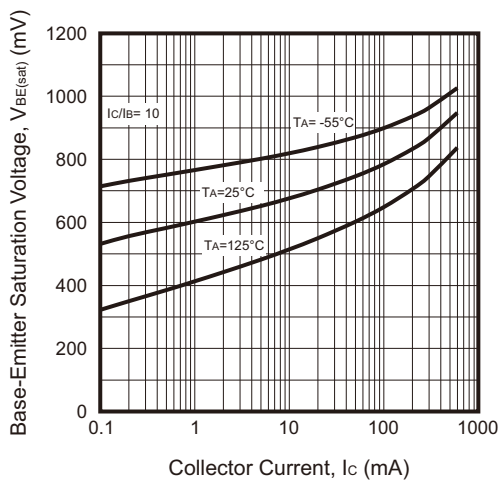
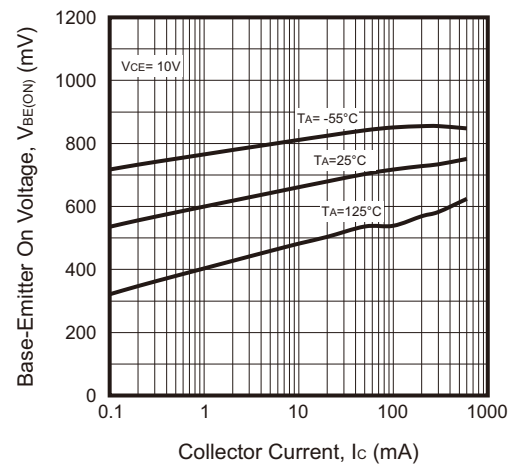
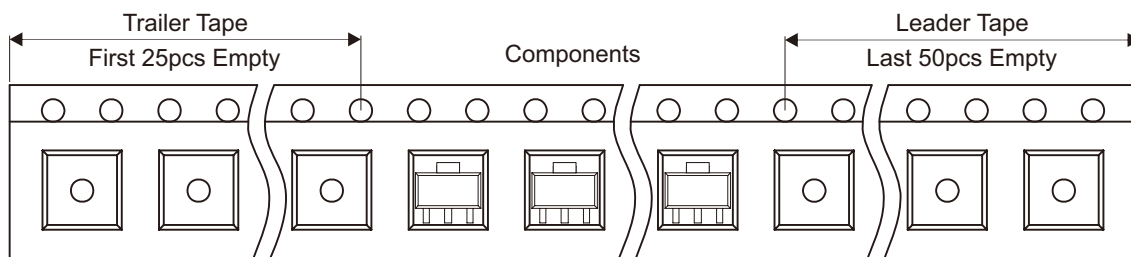
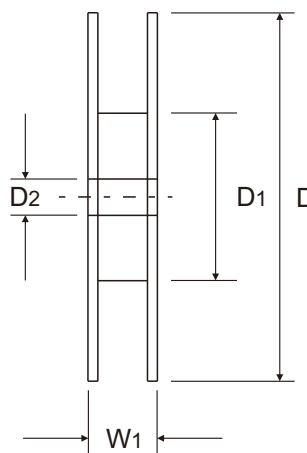
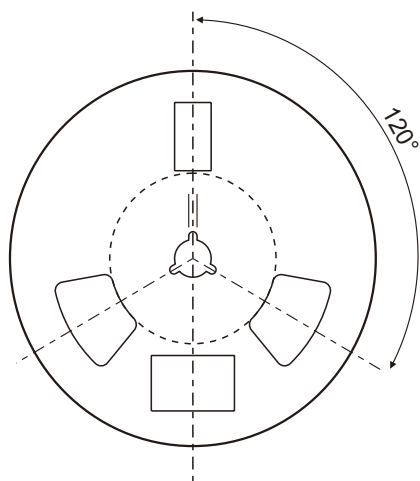
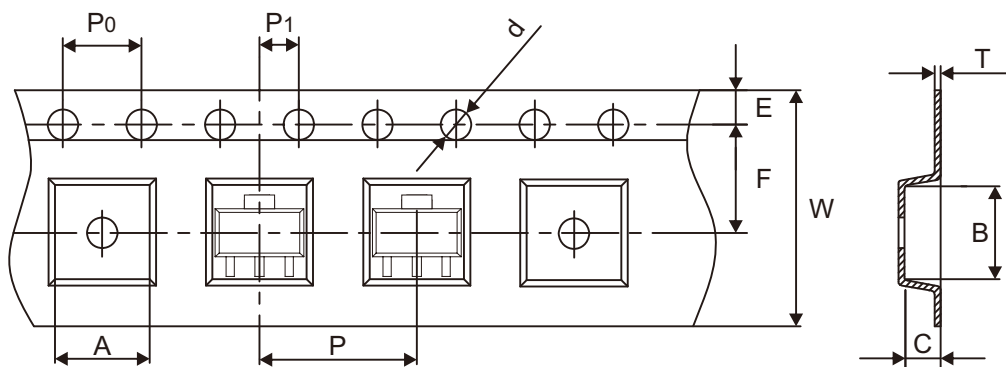

Fig.4 - $V_{BE(ON)} - I_c$



Reel Taping Specification



SOT-223	SYMBOL	A	B	C	d	D	D1	D2
	(mm)	7.05 ± 0.10	7.40 ± 0.10	1.90 ± 0.10	1.55 ± 0.05	330.00 ± 2.00	100.00 ± 2.00	13.00 ± 0.20
	(inch)	0.278 ± 0.004	0.291 ± 0.004	0.075 ± 0.004	0.061 ± 0.002	12.992 ± 0.079	3.937 ± 0.079	0.512 ± 0.008

SOT-223	SYMBOL	E	F	P	P0	P1	T	W	W1
	(mm)	1.75 ± 0.10	5.50 ± 0.10	8.00 ± 0.10	4.00 ± 0.10	2.00 ± 0.10	0.25 ± 0.05	12.00 + 0.30 - 0.10	18.50 ± 2.00
	(inch)	0.069 ± 0.004	0.217 ± 0.004	0.315 ± 0.004	0.157 ± 0.004	0.079 ± 0.004	0.010 ± 0.002	0.472 + 0.012 - 0.004	0.728 ± 0.079

Marking Code

Part Number	Marking Code
APZT2222A-HF	1P

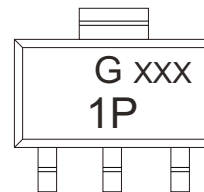

XXX = Control code

Suggested P.C.B. PAD Layout

SIZE	SOT-223	
	(mm)	(inch)
A	0.75	0.030
B	1.60	0.063
C	2.30	0.091
D	4.55	0.179
E	3.40	0.134
F	6.15	0.242
G	7.75	0.305

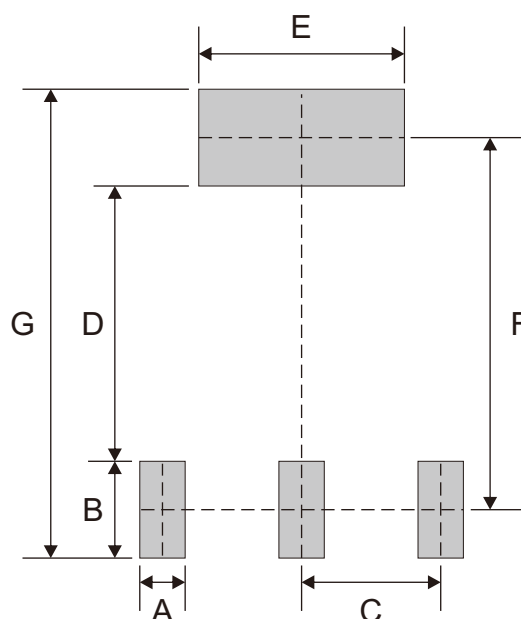

Standard Packaging

Case Type	REEL PACK	
	REEL (pcs)	Reel Size (inch)
SOT-223	4,000	13